

# Counter Balance

## PART NO

TED-ATT-018-00

The Counter Balance is designed to be mounted onto the back of the table therefore increasing the lifting capacity of the front attachments. The Counter Balance comes with removable legs allowing for quick mounting and removal.

## COMPLIES WITH

AS1170.0, AS1170.1, AS2359.1, AS2359.2, AS/ISO 22915.1

## SPECIFICATIONS

Attachment Type	TED
Safe Working Load	N/A
Mounting	Table
Tare Weight	235kg

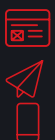
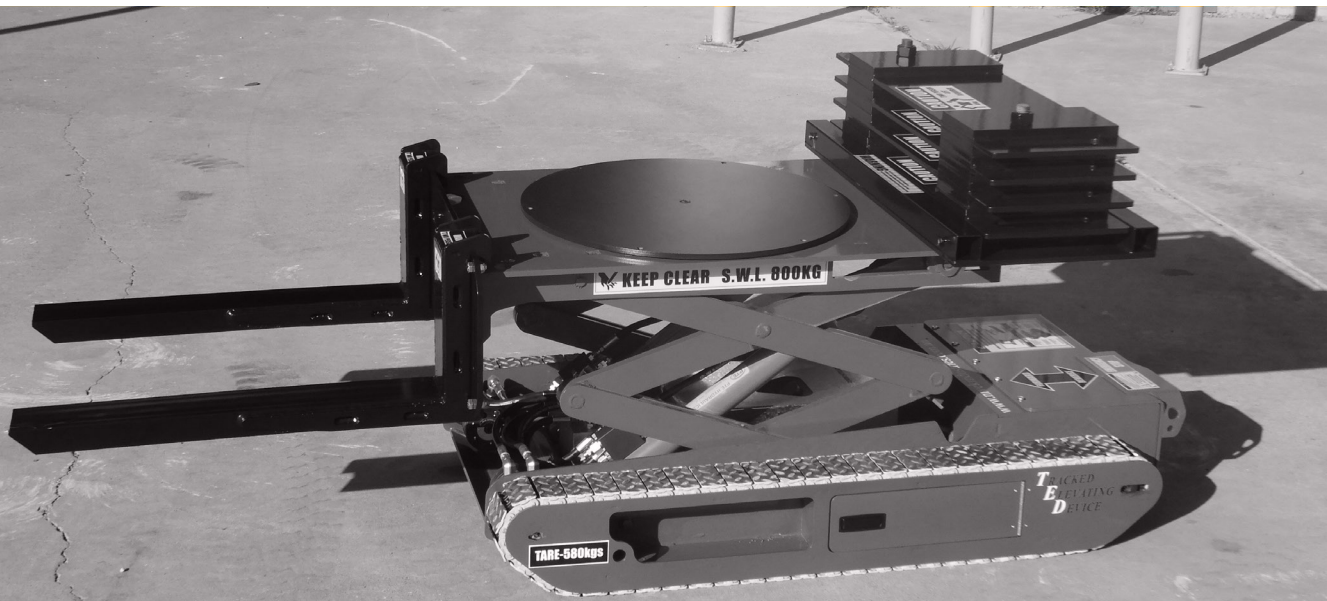
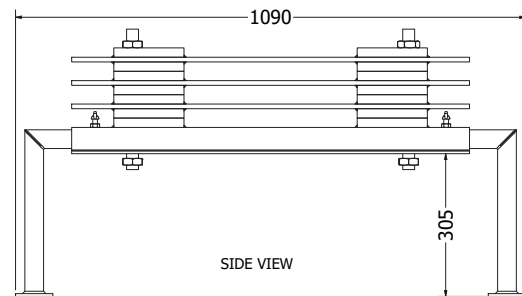
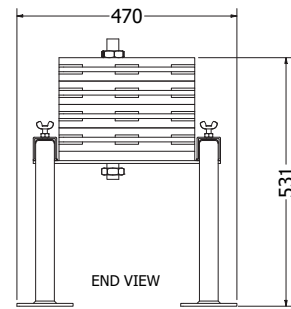
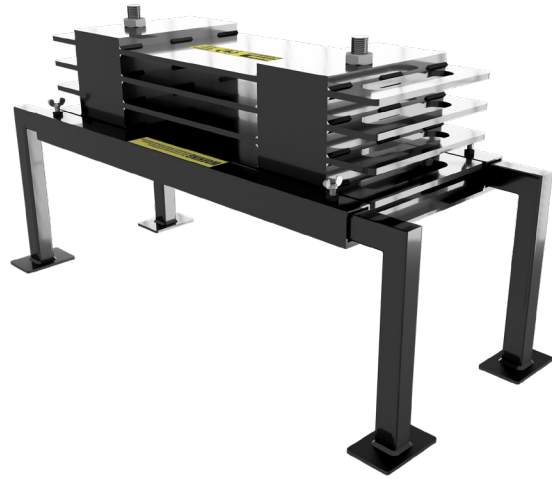

nivekindustries.com.au

sales@nivekindustries.com.au

+61 (0)400 675 531



**NIVEK**  
**INDUSTRIES**  
PTY LTD